



TS 83

Easy-action
Door Closer

Easy-action door closer with “thinking” backcheck

Easy to fix and even easier to adjust. The door closer for almost every door size and application.

Decades of experience have gone into the development of the DORMA TS 83. The result is user comfort coupled with outstanding versatility. It can be adjusted to suit almost all types of door.

It can even be supplied with additional anti-corrosion protection for exposed applications or aggressive conditions. Fixing couldn't be easier – and last but not least – it's engineered for excellence.

Certified to ISO 9001.

Plus points

For the trade

- Low inventory costs and reduced stocking requirements thanks to streamlined product range.
- Practical and effective solutions to meet special applications thanks to comprehensive choice of accessories.

For the installer

- Easy to fix.
- Can be “tailored” to the requirements of the door by simple adjustment.
- Just one model for RH (DIN-R, ISO 5) and LH (DIN-L, ISO 6) doors, and for standard and frame/lintel fixing.
- Spring strength range EN 3–6 to suit virtually every application.

For the specifier/architect

- Compact closer design and sturdy flat-form arm assembly.
- Wide range of standard functions supplemented by optional extras.
- Suitable for fire doors.

For the user

- Optimum wall and door protection thanks to “thinking” backcheck.
- Closing speed virtually unaffected by temperature fluctuations.
- Proportionately low opening resistance thanks to high mechanical efficiency.



The TS 83 conforms to most recognised international standards and complies with the

requirements and/or recommendations of the following: CERTIFIRE approved for fire doors; Ref. CF 118

Data and features		TS 83	
Variable closing force	Spring strength	EN 3 – 6	EN 7
Standard doors ¹⁾	≤ 1400 mm ≤ 1600 mm	● –	– ●
External doors, outward opening ¹⁾	≤ 1400 mm ≤ 1600 mm	● –	– ●
Fire and smoke check doors ¹⁾	≤ 1400 mm ≤ 1600 mm	● –	– ●
Non-handed		●	●
Arm assembly type	Standard	●	●
	Flat-form	●	●
	Slide channel	–	–
Closing force variable by means of adjustment screw		●	–
Closing speed adjustable at 2 separate valves	180° - 15°	●	–
	15° - 0°	●	–
Closing speed variable by means of valve adjustment		–	●
Adjustable latching action	by arm	●	●
Backcheck	self-regulating	●	●
	adjustable at valve	●	●
Delayed action variable at valve		○	–
Hold-open		○	○
Weight in kg		1.7	3.3
Dimensions in mm	Length	245	293
	Overall depth	46	47.5
	Height	60	60
Door closer tested to EN 1154		●	●
CE mark for construction products		●	●

● yes – no ○ option

¹⁾ For applications involving particularly heavy or wide doors, and doors which have to close against wind resistance, the next highest closer size or a higher spring strength should be applied.

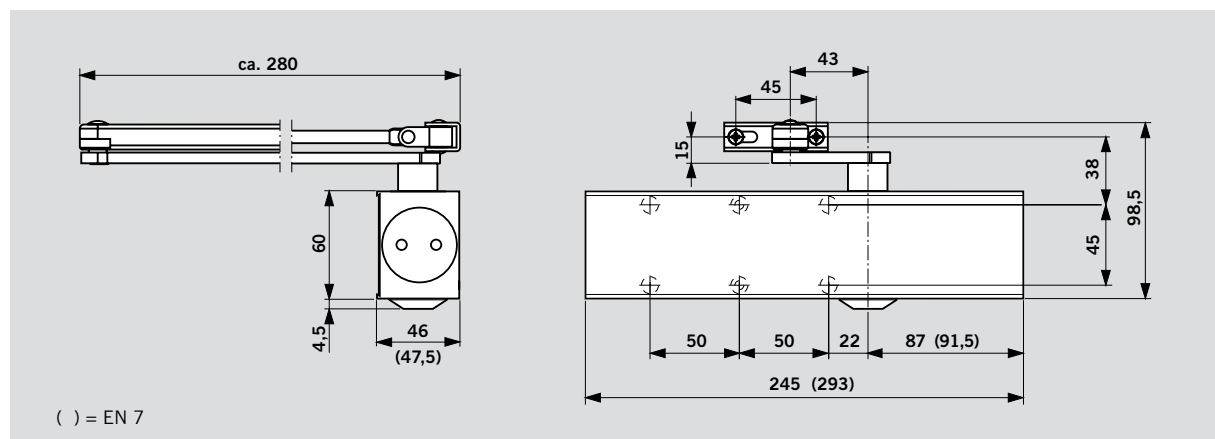

Standard and optional functions

With “thinking” backcheck – Model BC/ÖD

Thanks to an innovative design concept, the resistance developed by this backcheck system as the door is opened beyond approx. 70° is directly proportional to door acceleration. It is almost imperceptible when the door is opened slowly. However, if the door is opened hastily, the backcheck responds in equal measure.

And if the door should be flung open at speed – whether deliberately, thoughtlessly, accidentally or as a result of a gust of wind – the backcheck reacts at full strength, protecting the wall and door from damage.

If no backcheck function is required, the system can simply be switched off.

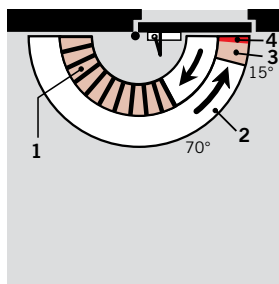

- 1 Self-regulating backcheck
- 2 Infinitely variable closing speed in the range 180° – 15°
- 3 Infinitely variable closing speed in the range 15° – 0°
- 4 Adjustable latch range (by arm)

With additional delayed action – Model BC/ÖD + DC/SV

This model with its additional, integrated delayed action enables the closing cycle to be retarded within an adjustable range from 180° – 70° so that disabled persons, mothers with prams and people carrying bulky items are able to pass through the door without difficulty.

This model can also be used for fire doors.

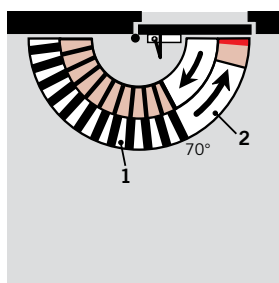
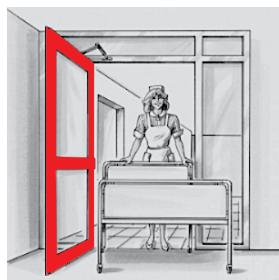

- 1 Adjustable delayed action
- 2 Fully controlled closing with adjustable speed

With hold-open – Model with hold-open arm

Combining the TS 83 with a hold-open arm enables the door to be held open at an appropriate angle (up to approx. 150°).

The hold-open function in the standard hold-open arm can be switched on and off by the user by simply pressing a switch.

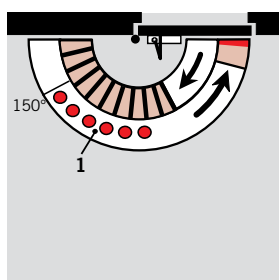
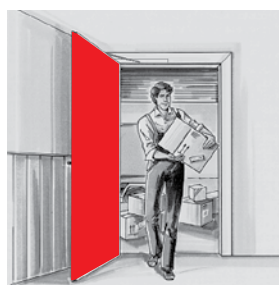

- 1 Hold-open range

Hold-open arms are not approved for fire and smoke check doors.

Door leaf fixing, pull side (example shows LH (ISO 6) door; RH (ISO 5) doors mirrored arrangement)

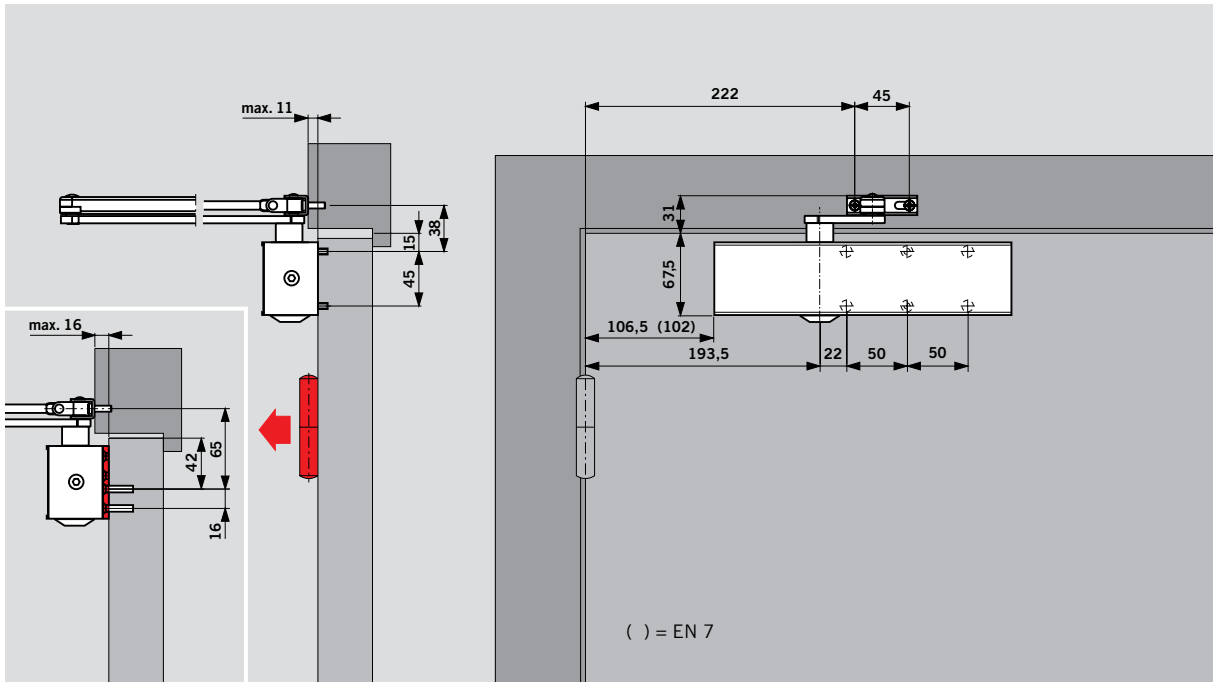

Door leaf fixing with hold-open arm

(example shows LH (ISO 6) door; RH (ISO 5) doors mirrored arrangement)

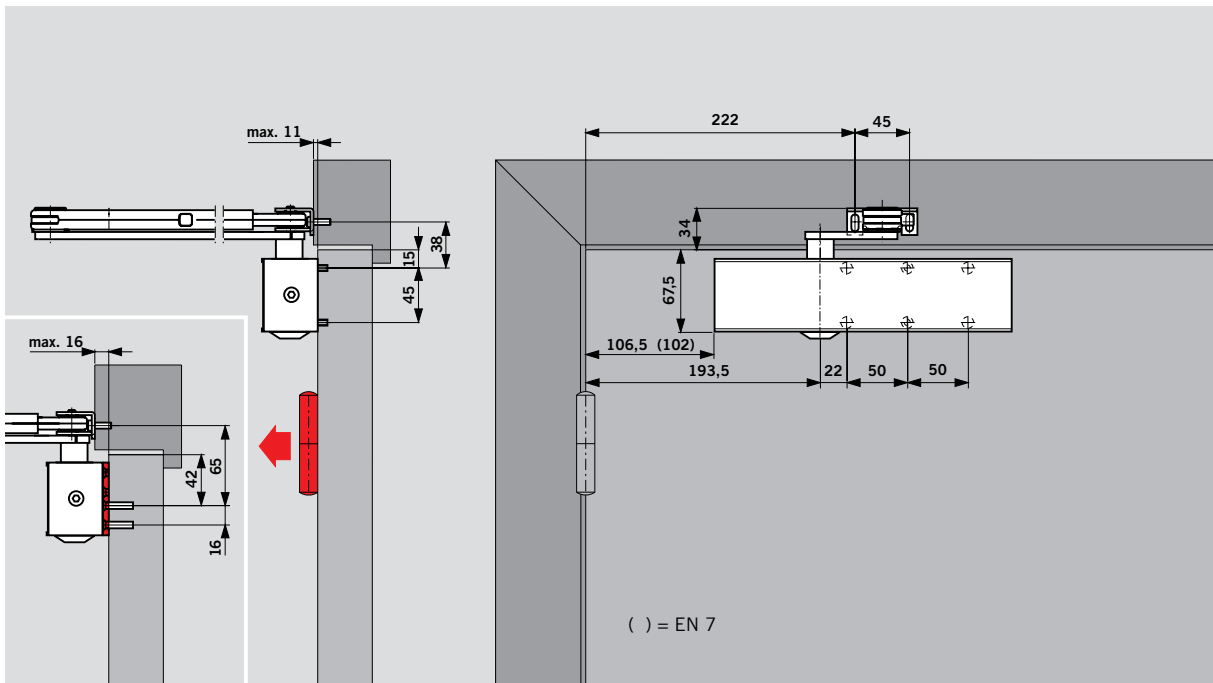

Transom fixing, push side (example shows LH (ISO 6) door; RH (ISO 5) doors mirrored arrangement)

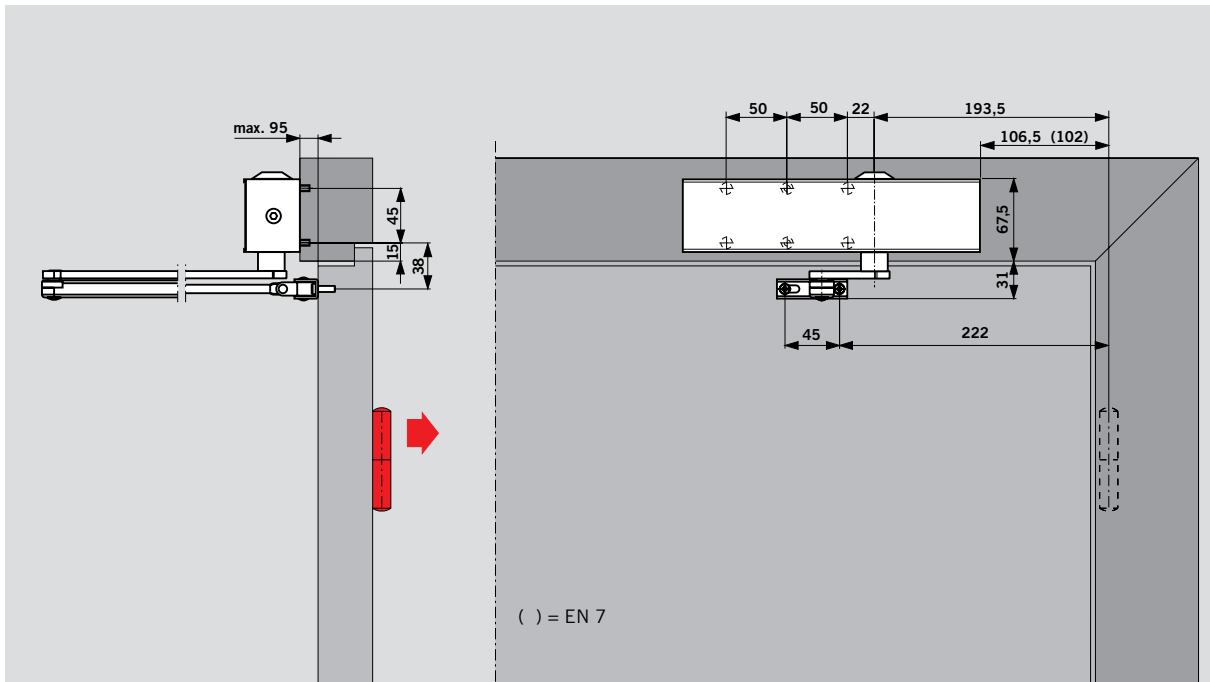

In the case of fire doors, door closers may only be transom-fixed where appropriate approval has been obtained in the form of a certificate or test report issued by an accredited testing agency.

Transom fixing:

With transom-fixed closers, the backcheck only responds at between 85° and 90°, depending on the depth of reveal and type of door hinge involved; the delayed action, on the other hand, releases the door at an earlier point in its closing sweep.

Mounting backplate TS 83

For use with fire and smoke check doors and also as an intermediate plate when direct fixing to the door is not possible; with fixing hole pattern to EN 1154, supplement 1.

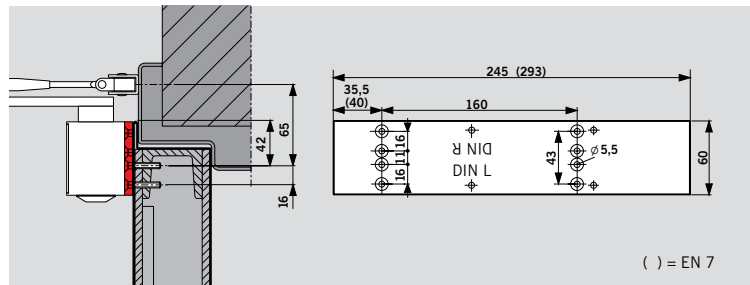

Arm bracket adapter plate TS 73 V / TS 83

For fixing the arm bracket to particularly narrow door frames.

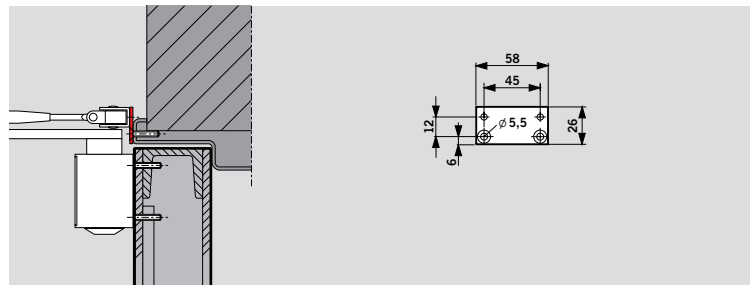

Angle bracket TS 83

For frame/lintel fixing of the closer on the push side of doors with deep reveals.

On fire and smoke check doors, proof of suitability required in relation to the individual door concerned.

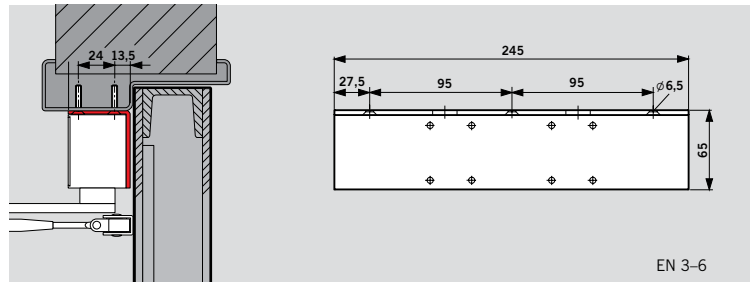

EN 3-6

Drop plate TS 73 V / TS 83

For installation on frame when direct fixing of closer is not possible.

On fire and smoke check doors, proof of suitability required in relation to the individual door concerned.

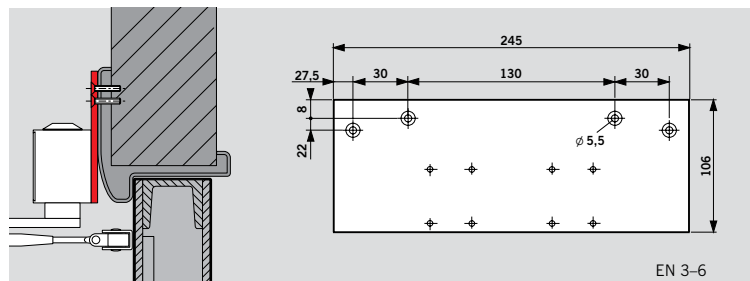

EN 3-6

Parallel arm bracket TS 73 V / TS 83

For parallel arm installation on the push side (see fixing instructions for dimensions).



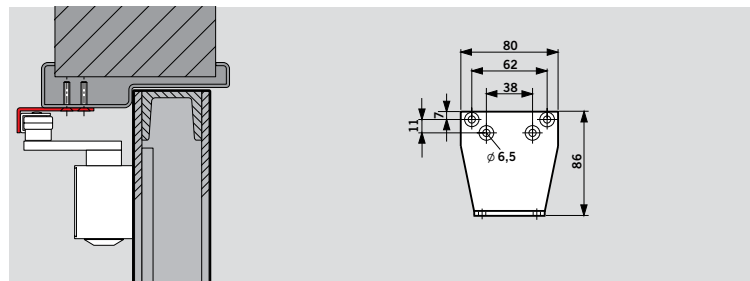





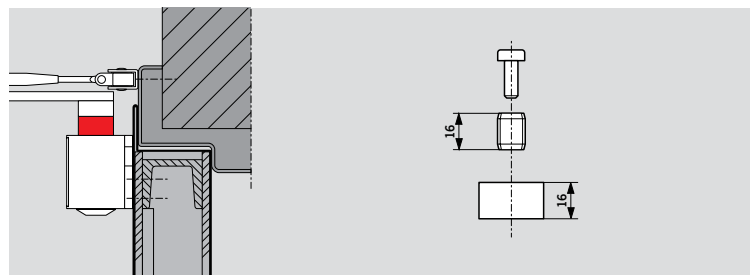

On fire and smoke check doors, proof of suitability required in relation to the individual door concerned.

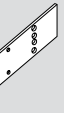

Spindle extension TS 73 V / TS 83

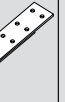
For increasing the distance between the closer and the arm assembly in the case of doors with a high overlap; 16 mm high.



Supply and accessory information										
Closer body TS 83 	Standard arm  □ 220023xx	Standard arm anti-corrosive type (AC) 	Flat-form arm  □ 830001xx	Hold-open arm with on/off switch  □ 220030xx	Mounting backplate  EN 3 – 6 380001xx EN 7 830011xx	Arm bracket adapter plate  830014xx	Angle bracket  EN 3 – 6 380003xx	Drop plate  EN 3 – 6 380002xx	Parallel arm bracket  280066xx	Spindle extension 16 mm  83003705
Size EN 3 – 6 BC/ÖD ■ 380101xx	□		□	□	#	#	#	#	#	#
Size EN 3 – 6 BC/ÖD+DC/SV ■ 380201xx	□		□	□	#	#	#	#	#	#
Size EN 3 – 6 BC/ÖD (AC)		■ 38030301			#	#	#	#	#	#
Size EN 7 BC/ÖD ■ 830501xx	□		□	□	#	#			#	#

Order No.:
 ■ = Body only
 □ = Arm only
 ■□ = Closer with arm, complete
 # = Optional accessory

Colour*)
 silver 01
 white (RAL 9016) 11
 other 09

*Anti-corrosion protected closers and arms available in silver (01) only.

Specification text TS 83 EN 3 – 6

DORMA TS 83 rack and pinion door closer; with adjustable power size EN 3 – 6, according to EN 1154, carries the CE mark, integral self-regulating backcheck; closing speed adjustable in two independent ranges and adjustable latch action. Non-handed.

Model
 with additional, adjustable delayed action
 anti-corrosion protected (AC)
 with standard arm
 with flatform arm
 with hold-open arm with switch

Accessories

Colour
 silver
 white (sim. RAL 9016)
 other (sim. RAL _____)

Model make DORMA TS 83
 TS83

Specification text TS 83 EN 7

DORMA TS 83 rack and pinion door closer; with power size EN 7, according to EN 1154, carries the CE mark, integral self-regulating backcheck; adjustable closing speed and adjustable latch range. Non-handed.

Model
 with standard arm
 with flatform arm
 with hold-open arm with switch

Accessories

Colour
 silver
 white (sim. RAL 9016)
 other (sim. RAL _____)

Model make DORMA TS 83
 TS83



www.dorma.com

Subject to change without notice

WN 053 236 51532, 09/11, TS 83, GB, X, XX, xx/11



DORMA GmbH + Co. KG
DORMA Platz 1
D-58256 Ennepetal
Phone +49 2333 793-0
Fax +49 2333 793-4950